

Development, evolution and technical characteristics of small wind systems (SWT) as a new technology for the production of renewable energy

Francesco Matteucci
Consultant of Ravenna Province

Distributed Generation Systems (DGs)

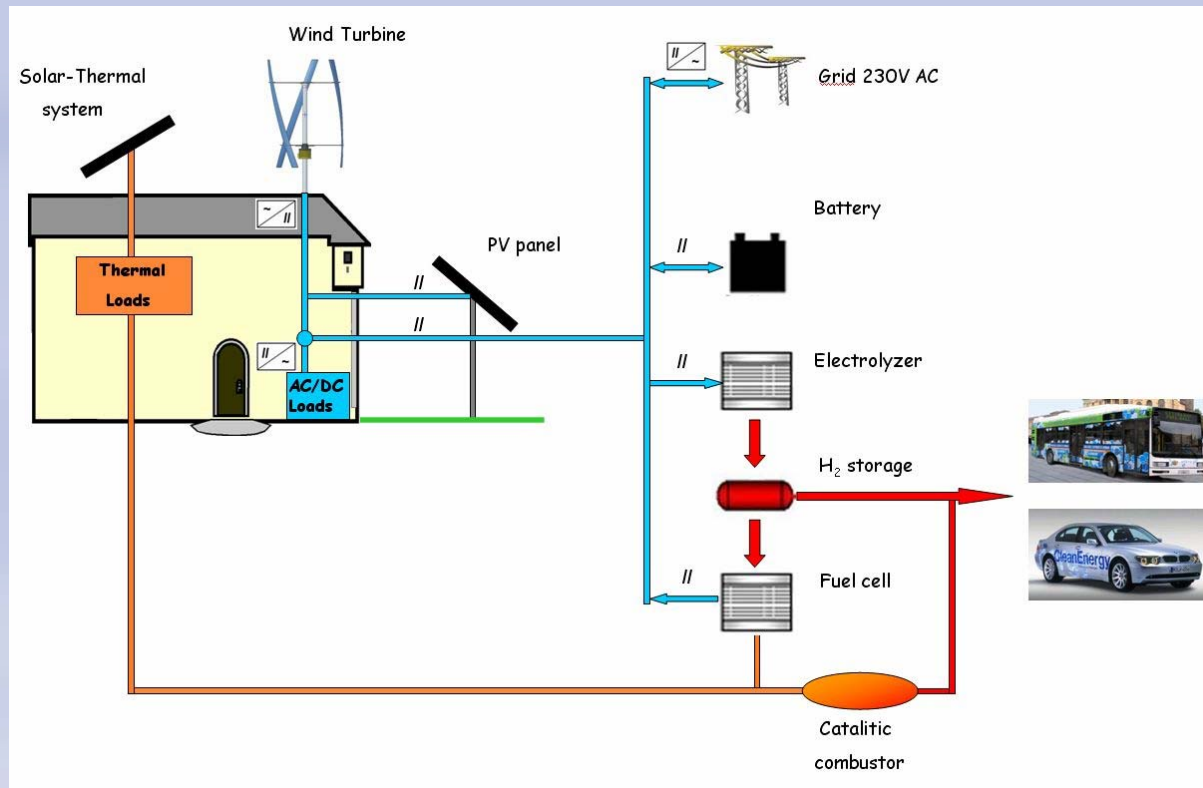

SWT Market Actors

Manufacturers (wind turbines reliability)

Municipality (authorization procedure)

Customer (technical issues)

Bank (“easy” technical advisory)

Classification of Small Wind turbines (SWT)

- 1- Based on nominal output power
(typical of administration, but not correct for economical or technical application)
- 2- Based on swept area
(taken from IEC 61400 gives the possibility of making correct evaluation both for economical and AEO (annual energy output) purposes)
- 3- Based on site of application of the SWT
(this method might be useful for enviromental planner)

Critical issues for SWT

Feed in tariff or incentives
(different ways of evaluating such values)

Authorization procedure
(different paths, but mainly related to the environmental impact, grid requirements, noise emissions, ...)

Reliability of SWT
(the reference is IEC 61400, but there are country rules (MCS, SWCC), besides is mandatory CE label)

Critical issues for SWT

Wind resource assessment
(different methods of evaluating such values)

Installation procedure
(different ways mainly with or without crane also depending upon the type of tower)

O&M
(different contracts or services)

Financing from Bank

Wind Resource Assessment 1

SENSORS FOR MEASURING WIND SPEED



SENSORS FOR MEASURING WIND DIRECTION AND TEMPERATURE AND ATMOSPHERIC PRESSURE



Wind Resource Assessment 2

Starting from satellite data or meteorological data and merging them with the surface topography you can get reliable data of wind resource at different hub height.

There are several mathematical modelling methods to do such evaluation but the best improvements has been recently given by the use of “powerful” hardware that allows you to perform such analysis in few weeks instead of many months.

Nowadays such methods are gaining much interest but their actual limit is its acceptance by the bank as a reliable and “bankable” way of evaluating wind resource and therefore calculate the AEO (business plan).

SWT Applications in WiCo

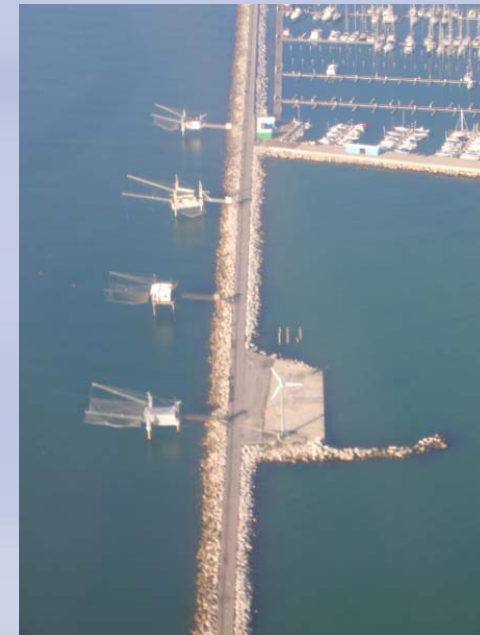

SWT Applications in Urban Areas



SWT Installation in Open Areas

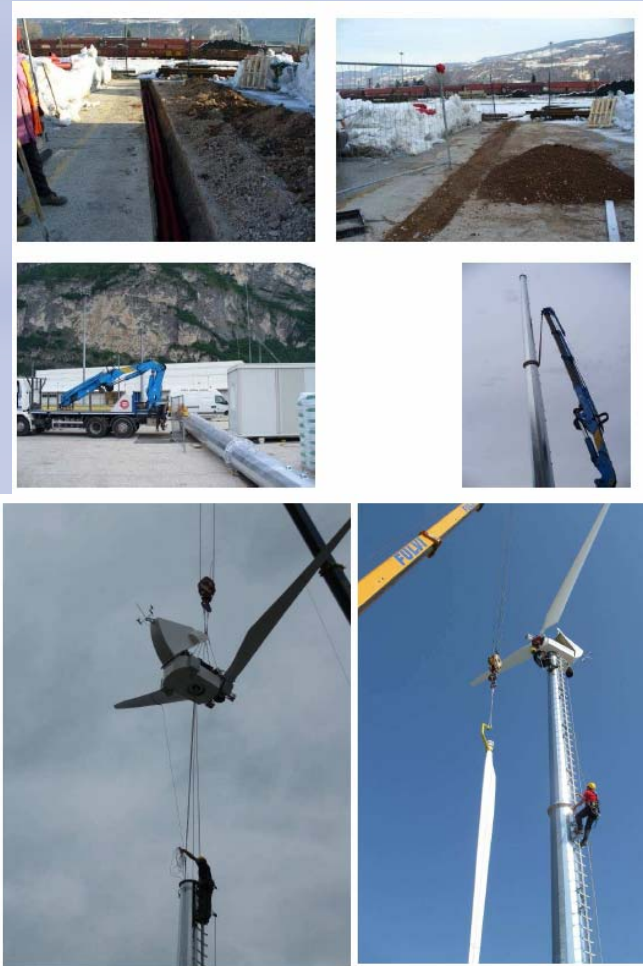
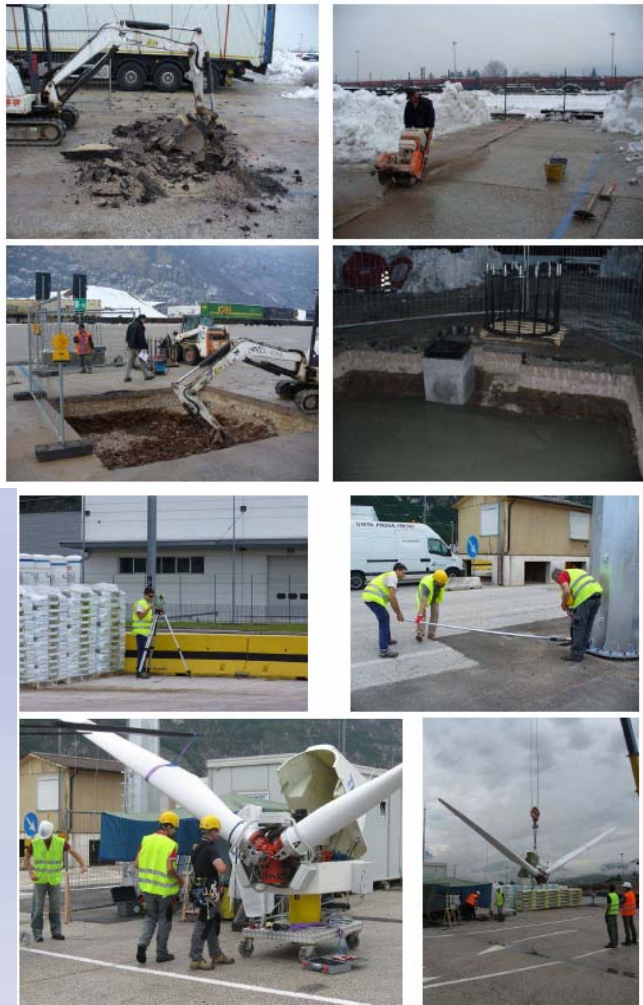

SWT Installation in Urban Areas

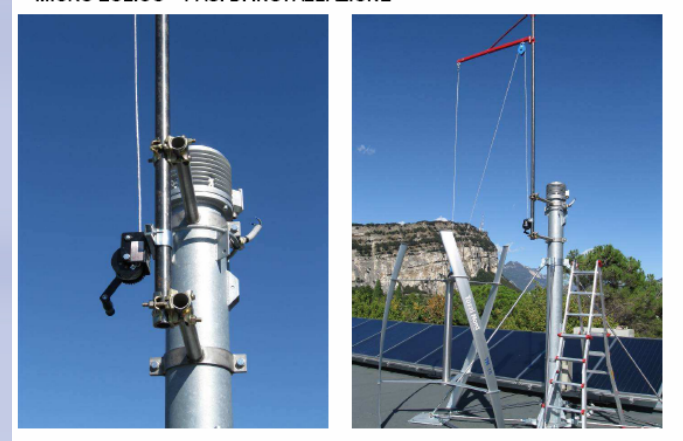

Thanks for the attention

Francesco Matteucci
Consultant of Ravenna Province